

#201040, 201050, 201100, 201110 CHROME BILLET OIL COOLER



Please read and understand these instructions completely before installation to avoid any possible injury to yourself or the motorcycle and/or accessory.

NOTE: INSTALLATION SHOULD BE PERFORMED ONLY BY QUALIFIED PERSONNEL.

PARTS LIST:		QTY:
#1	OIL COOLER TUBE & ELEMENT	1
#2	#6 AN TO 1/4 NPT FITTING	2
#3	OIL COOLER CLAMP	1

TC88 NOTE:
FOR TC88 A & B MOTORS, A
"SANDWICH" TYPE ADAPTER IS
INSTALLED UNDER THE OIL FILTER.
ROUTE THE OIL LINES PER THE
MANUFACTURER'S INSTRUCTIONS.

OIL LINE ROUTING-EVO APPLICATION:

1. Install the two #6 AN Fittings into the bottom of the Oil Cooler. Use teflon tape or suitable liquid pipe sealer.
2. **Refer to FIG. A.** This schematic shows the basic routing of oil lines (not included) from the Oil Pump, to the Filter Adapter (not included), to the Oil Cooler, and back to the Oil Tank on an EVO motor.
3. **Refer to FIG. B.** This photo shows the location of the Inside and Outside oil line fittings. The Inside Fitting on your oil filter adapter is for the oil line FROM the oil pump. The Outside Fitting is for the oil line that will go to one of the #6 AN Fittings on the Oil Cooler. The remaining #6 AN Fitting on the Oil Cooler is for the return line back to the oil tank.

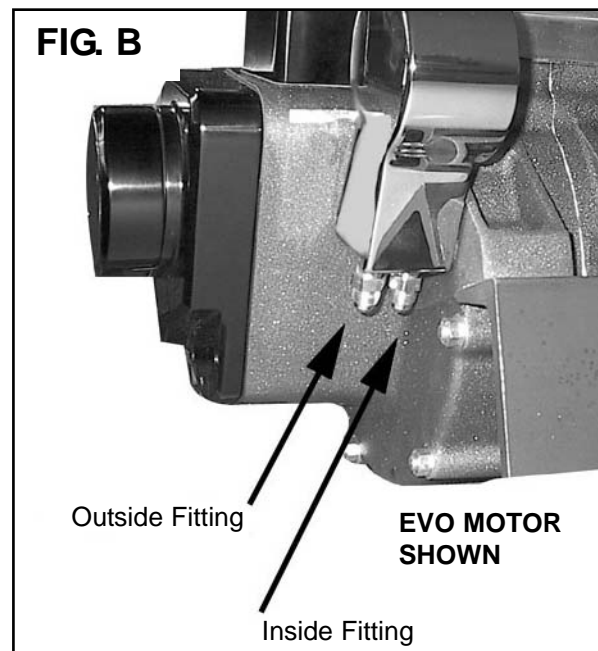
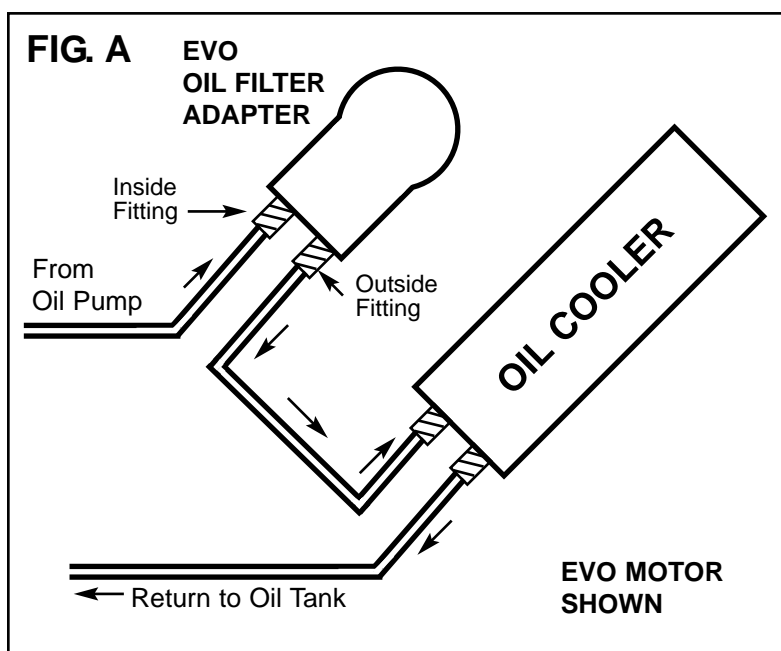

IF YOU NEED ASSISTANCE WITH THIS PRODUCT CONTACT PRO-ONE AT: 800-884-4173