

#400350 & #400360 BULLET LIGHT KIT UNIVERSAL APPLICATION



THESE LIGHTS ARE A **UNIVERSAL APPLICATION** AND CAN BE ADAPTED TO MOST BRANDS OF MOTORCYCLES. IF YOU ARE INSTALLING THEM ON A **YAMAHA ROAD STAR**, FOLLOW THE SPECIAL INSTRUCTIONS BELOW.

WARNING: USE FOR TURN-SIGNAL LIGHTS ONLY! DO NOT USE AS RUNNING LIGHTS. OVERHEATING WILL RESULT AND THE LENS WILL MELT!

PARTS LIST:

<u>ITEM:</u>	<u>PART NAME:</u>	<u>DESCRIPTION:</u>	<u>QTY.</u>
#1	BULLET LIGHT W/ 5/8" MOUNTING BOLT	SUPPLIED	2
#2	WASHER	SUPPLIED	2
#3	3/8-16 x 1-1/4" BOLT	SUPPLIED	2

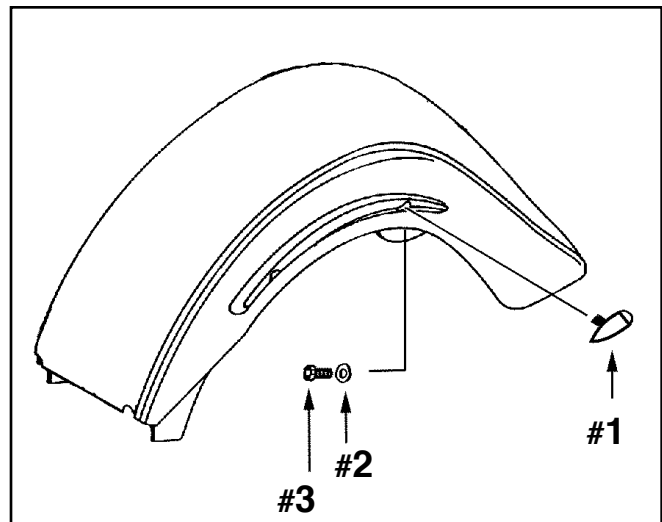
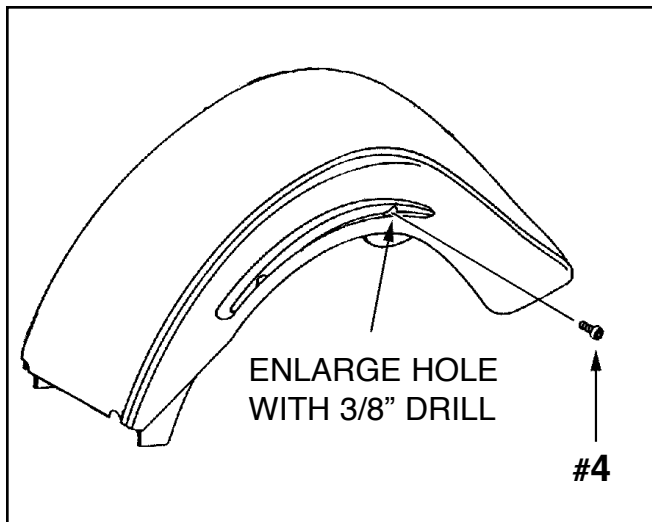

WARNING: USE FOR TURN-SIGNAL LIGHTS ONLY! DO NOT USE AS RUNNING LIGHTS. OVERHEATING WILL RESULT AND THE LENS WILL MELT!

SPECIAL INSTRUCTIONS FOR YAMAHA ROAD STAR INSTALLATION: REQUIRED; 3/8" DRILL BIT.

1. Remove Rear Wheel and rear Turn-signal assembly.
2. Remove the stock 6mm screw (#4) as shown in Fig. 1 above. Locate and unplug the turn signal power leads from their connectors.
3. The mounting hole must be enlarged using a 3/8" drill bit.
4. Guide the wire from the Bullet Light (#1) through the mounting hole and then through the washer (#2) and the 3/8-16 x 1-1/4" Bolt (#3) as shown in Fig. 2 above. Align the Bullet Light to the proper angle and tighten the bolt.
5. Plug the male bullet connector from the Bullet Light into the female connector from the stock turn signal power lead.

NOTE: A PROPER GROUND MUST BE PROVIDED FOR THE BULLET LIGHTS. ON SOME MODELS, YOU MUST EITHER GROUND THE FENDER OR ONE OF THE BULLET LIGHTS.

2700 Melbourne Ave. Pomona, CA. 91767 PH. 909-445-0900 FAX: 909-445-0096